

A scalable neutron source for detector radiation hardness test*

E. Friske¹ and H. R. Schmidt^{1,2}

¹Universität Tübingen, Tübingen, Germany; ²GSI, Darmstadt, Germany

Silicon detector radiation hardness

During operation of the STS, the silicon strip detectors are expected to be irradiated with large numbers of neutrons, some sectors in excess of 10^{12} $n_{\text{eq}}/\text{cm}^2/\text{month}$ [1], with an accumulated dose of 10^{14} $n_{\text{eq}}/\text{cm}^2$ [3].

To test detector performance and particularly changes in the semiconducting properties due to neutron induced activation, a neutron source with high flux is necessary. Unfortunately, reactors with sufficient neutron flux are heavily occupied. This leads to irradiation campaigns with very short irradiation times (in the order of minutes) in which the desired neutron dose is achieved [2].

To get a more realistic representation of the irradiation process, an exposure of days or weeks with defined annealing phases is more desirable. To fulfill these goals a scalable neutron source with good accessibility is required.

Neutron source

Present source The current neutron source consists of a gas cell filled with deuterium gas under a pressure of a few bar. A 2 MeV deuteron beam from the Rosenau accelerator passes an entrance window of a few microns thickness to induce deuterium fusion. However, even at this thickness the heat load on the entrance window reduced its mechanical stability, limiting both the beam current and the pressure of the gas cell.

Due to the limitations of both the accelerator and the window currently the neutron production is limited to a rate of $\approx 10^{12} n_{\text{eq}}/\text{cm}^2/\text{week}$. As this rate is about two orders of magnitude below the required total dose, it would take way too long to accumulate with the current setup. To solve these issues, a new gas cell is currently being manufactured, based on [4].

Cryogenic source The new neutron source currently in production consists of a steel endcap for the accelerator beam pipe. Mounted inside the endcap is the actual cell, cooled by liquid nitrogen. In contrast to [4], the gas cell is cooled by a copper finger reaching into a liquid nitrogen dewar. The entrance window is fixed to a thick copper disk sealing off the gas cell. (A technical sketch is shown in Fig. 1.)

This setup has several advantages over the present cell: The enclosed deuterium gas is more dense by a factor of 4 compared to room temperature, and the lower ambient

temperature should increase the durability of the entrance window, allowing higher beam currents.

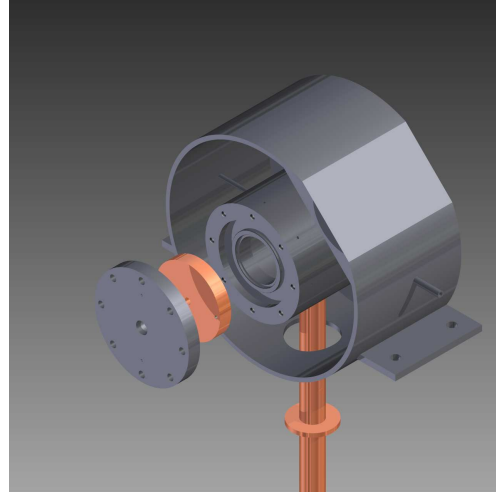

Figure 1: Schematic view of the cryogenic source

Combining these effects, it should be possible to increase both beam current and beam energy (to the accelerator's limit), which both significantly increases the neutron yield. In addition, the detector can be put within a few cm of the gas cell, providing maximum solid angle coverage. These improvements should increase the neutron flux by at least one order of magnitude, but the actual gain has to be determined once the cryogenic source is operational. Before the new source can be put into operation additional tasks have to be performed, including tests of possible window materials and the cooling system.

References

- [1] V. (eds.) Friese and C. C. Sturm. CBM progress report 2013, 04 2013.
- [2] Singla, M. [GSI, Darmstadt]. Development of radiation tolerant microstrip sensors for the CBM silicon tracking system, 03 2014.
- [3] Sorokin, I. [Frankfurt University]. *Characterization of silicon microstrip sensors, front-end electronics, and prototype tracking detectors for the CBM experiment at FAIR*. PhD thesis, 04 2014.
- [4] W. Von Witsch and J. G. Willaschek. High-pressure gas target for the production of intense fast-neutron beams. *Nuclear Instruments and Methods*, 138:13–17, Oct. 1976.

* Work supported by GSI(CBM).