

Low and high voltage powering concept for the CBM Silicon Tracking System

C.J.Schmidt¹ and P. Koczoń¹

¹GSI, Darmstadt, Germany

Due to the radiation damage of the silicon sensors of CBM-STs detector their performance will deteriorate in course of experimental activity. Gradual increasing of their depletion voltage will improve the efficiency again and prolongate their life time. This procedure will be applied for each one of almost 1000 sensors separately what forces floating low and high voltage power supply architecture.

Requirements for low voltage powering of one silicon sensor.

The silicon Tracking System of CBM will be operated together with Micro Vertex Detector inside the magnetic field of 1 Tesla and rather small volume of about 1 m³ [1]. To minimise the scattering of the reaction products tracked by the system only silicon sensors, their supporting structure and signal cables will be installed inside of the detector acceptance. The readout and converting electronics and its cooling as well as power converter will be installed on the detector circumference. Altogether almost 40kW of heat has to be removed from STS box to reach working conditions of -5 °C for silicon sensors. All the cooling system tubing, low and high voltage cabling, data transmission and control links sockets have to be connected on only 1.5 m² of surface of the upstream wall of the detector housing. At least two different voltages are necessary for the STSxyter readout ASIC [3, 4] and additional two for the GBTx [5] and optical converter.

be as close as possible to the front end ASIC in order to minimise amount of the noise irradiated into the system. High depletion voltage (low current) can be generated and controlled from the outside of the STS volume. All used electronic parts inside the STS box should be radiation hard and should stand a magnetic field strength of at least 1T.

Proposed powering for CBM-STs detector

The schematic diagram in Fig.1 shows proposed power distribution system. Both sides of the sensor (central part in Fig.1) are supplied with positive and negative depletion voltage generated outside of the magnetic field (+200V and -200V in this case, red lines in Fig.1) with a common grounding. Sensor's strips are connected to the STS-xyter readout ASIC on the Front Electronic Board FEB with micro-cables (orange elements in Fig.1). ASICs powering of 2.2V and ca 4A (per FEB) will be generated by FEAST DC/DC converter placed on the side part of the cooling plate [2]. It supplies two LDOs converting the input voltage to 1.8V (digital) and 1.2V (analog part) of ASIC. The latter has to be grounded in the sensor vicinity to +200V or -200V respectively. Input power of 12V and about 1A is delivered from outside for each sensor separately. This construction minimises grounding loops and assures separation of strong and weak current flow. A GBTx chip is equipped with many e-links and can communicate with more than one FEB simultaneously so GBTx circuitry has to be galvanically isolated from STSxyter chips. GBTx and optical interface require their own power which will be generated from dedicated 12V lines and additional FEAST converters (uppermost and lowermost parts in Fig.1 in green). STSxyter as well as GBTx power stabilisation will be realised by LDO components placed directly on corresponding PCB boards. Vertical dashed line in Fig.1 depicts the boarder of the high irradiation and magnetic field region (front wall of the STS detector box) and little circles – electrical connectors to the high (in red) and low (in blue) voltage DC generators.

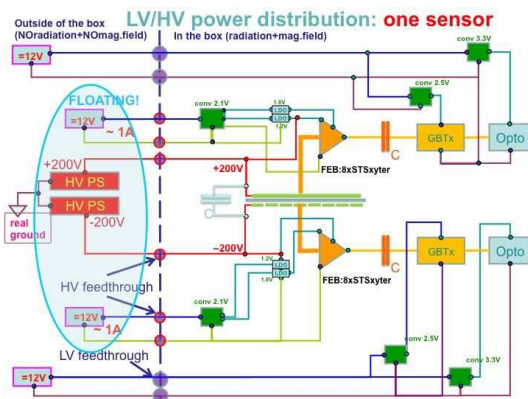

Figure 1: Low and high voltage powering of one silicon sensor.

Each sensor will be operated in a floating manner, e.g. p- and n-side will sense one half of the depletion potential (positive and negative) and the readout ASICs (and its powering) has to be applied "on top" of the sensors' depletion voltage. The last component shaping low voltage should

References

- [1] CBM STS Technical Design Report, 2012
- [2] <http://project-dcdc.web.cern.ch/project-dcdc/>
- [3] <http://repository.gsi.de/record/51956/files/PHN-NQM-EXP-22.pdf>
- [4] Nuclear Science Symposium and Medical Imaging Conference (NSS/MIC), 2013 IEEE
- [5] GBTx Project: <https://indico.cern.ch/event/113796/session/7/contribution/37/material/slides/0.pdf>