

Verification of the longitudinal feedback topology in SIS18*

K. Groß^{†1}, U. Hartel², H. Klingbeil^{1,2}, U. Laier², D. Lens², K.-P. Ningel², S. Schäfer², and B. Zipfel²

¹TEMF, TU Darmstadt, Germany; ²GSI, Darmstadt, Germany

Introduction

To damp oscillations of bunched beams, SIS100 will be equipped with a bunch-by-bunch (BxB) longitudinal feedback system (LFB). This helps to stabilize the beam, to keep longitudinal emittance blow up low and to minimize beam losses. The proposed LLRF topology of the closed loop system is, in some aspects, similar to the beam phase control system [1]. The difference and challenge is mainly the BxB signal processing followed by the generation of a correction voltage in dedicated feedback cavities. The adapted topology was verified at SIS18 during a beam time in 2014 using LLRF prototype subsystems and the two ferrite acceleration cavities.

Experimental Setup

Instead of applying the frequency correction Δf to the group DDS, i.e. to *all accelerating cavities*, the phase correction $\Delta\varphi$ is converted into an additional, phase shifted RF signal Δu and fed into *dedicated feedback cavities* resulting in an I/Q modulation of the total voltage u_{total} seen by the beam (Fig. 1, bottom right). Copies of the setups shown in Fig. 1 are used to determine the excitation and the required correction voltage for each bunch (and mode). The gray-shaded paths were cut to length to reach all interaction points with the same time delay. During acceleration, the phase $\varphi(f)$ has to be set according to the frequency-dependent phase response of LLRF components and cavity system.

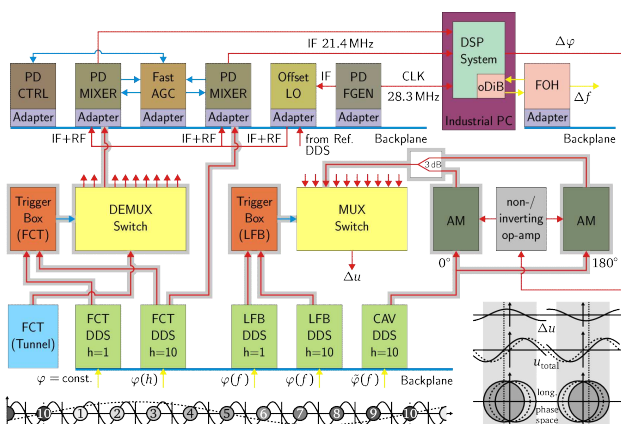

Figure 1: Sketch of LLRF of beam phase control system [2, 3] (top) with modifications for the LFB system (center) and principles of operation (bottom).

* Work supported by the German Federal Ministry of Education and Research (BMBF) under the project 05P12RDRBF.

[†] gross@temf.tu-darmstadt.de

Measurement Results

In 2014 individual bunches have been tracked several times over complete SIS cycles at harmonic number $h = 2$ and $h = 4$. In particular, coupled bunch oscillations (Fig. 2), as intentionally excited on Oct. 16th, can now be detected using the DDS-triggered demultiplexing of the beam signal (Fig. 1, bottom left).

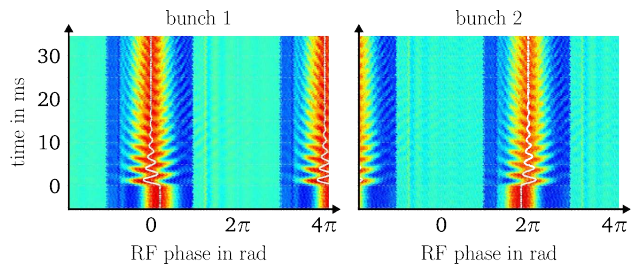

Figure 2: Waterfall plot of single bunches at $h = 2$ with BxB phase detection $\Delta\varphi$ (white lines) using one DSP system per bunch for an out-of-phase excitation.

A triggered LLRF signal (Fig. 3, left) providing the correction voltage for an individual bunch (cf. Fig. 2, left) at flattop was generated for the first time on Oct. 18th. The achieved damping of dipolar bunch oscillations shown in Fig. 3 (right) is a *proof of principle* for the proposed topology of the longitudinal feedback system.

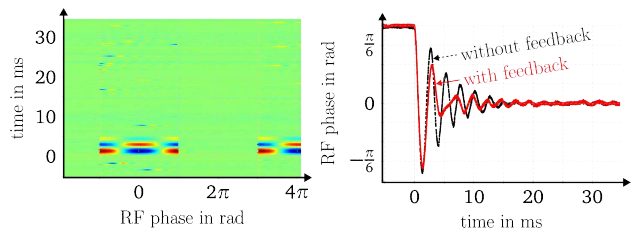

Figure 3: BxB LLRF correction signal Δu (left). Damping of dipole oscillations in SIS18 on Oct. 18th, 2014 (right).

The authors would like to thank D. Ondreka and H. Liebermann for the support and the customized machine setup which allowed to use one of the two main ferrite cavities as dedicated feedback cavity.

References

- [1] Klingbeil et al., IEEE Trans. Nuc. Sci., Vol. 54, No. 6 (2007).
- [2] Klingbeil, Laier, Regelsystemtopologie SIS18, internal note, revision 1.00, GSI (2009).
- [3] Laier, SIS HF Phasen Synchronisationstopologie, internal note, revision 1.50, GSI (2011).