

Engineering Study of the SIS100 Radiation Resistant Quadrupole Magnet Environment

N. Pyka¹, A. Kalimov², U. Kopf³, and C. Mühle¹

¹GSI, Darmstadt, Germany, ²State Polytechnic University, St. Petersburg, Russia; ³PROCAD GmbH, Kleinheubach, Germany

A part of the extraction area of SIS100 is exposed to unavoidable particle loss during beam operation [1, 2]. The origin may be due to ion beam halo or due to ion beam losses during slow extraction. These losses will mainly be deposited into a dedicated radiation resistant quadrupole magnet doublet [3]. These magnets will be highly activated. Hence, maintenance will be extremely difficult if not impossible. A particular challenge would be the handling of heating devices to re-establish the necessary XHV conditions inside the beam pipe after a vacuum break. For this reason an automatic device has been designed to drive apart the magnet and position a heater box around the vacuum chamber. After the heating process has been finished, the heater box will be removed and the magnets are automatically repositioned properly. This special quadrupole doublet is located in cell-2 of sector-5 of SIS100.

Adjustment and moving device

The adjustment and moving device for these quadrupole magnets is rather challenging. It has to be very stable since each side of the magnet weighs several tons. High rigidity is demanded since neither deformation nor torque is acceptable in order to assure reproducible movements and to withstand magnetic forces during operation. Lastly, in the final phase of closure the iron yoke and the coils have to match into the fits. Beyond that, the available space for this device is restricted to all sides by other installed equipment.

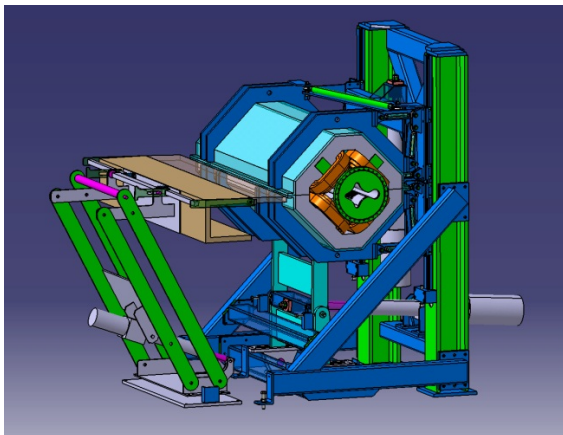

Figure 1: One radiation resistant quadrupole magnet in normal position hold by its adjustment and moving device; heater box on the left hand side in standby position. The vacuum chamber -beam pipe- is located between the coils.

The quadrupole magnet is symmetrically divided into an upper and lower part with a support structure around to absorb the forces during operation at high current. Each coil has to be installed separately in advance into one quarter of the iron yoke. The coil is mechanically fixed inside the mould of the yoke. Afterwards, two quarter of yoke and coil are mounted together via a thick sheet plate which itself is stabilized and hold by reinforcement stirrups. The latter are connected with the main holding structure via suspension bars.

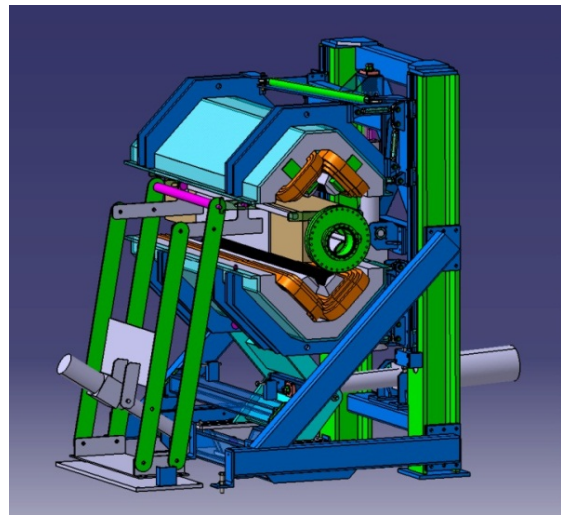

Figure 2: The quadrupole magnet opened with the beam pipe heater box in heating position.

On the basis of the existing design, the final construction and building of the adjustment and moving device can be placed. A careful adjustment and test phase of the whole assembly including the magnet has to follow the delivery before a fully automated routine operation can start.

References

- [1] N. Pyka, et al., GSI Scientific Report 2009, Darmstadt, 2010, p. 98.
- [2] A. Sokolov, et al., GSI Scientific Report 2011, Darmstadt, May 2012, p. 354.
- [3] A. Kalimov, Radiation Resistant Quadrupole for SIS100, GSI Internal Report (2012).