

Development of a high current gas discharge switch for the FAIR magnetic horn*

C. Hock¹, B. Brünner¹, A. Faber¹, M. Iberler¹, J. Jacoby¹, G. Loisch¹, A. Schönlein¹ and J. Wiechula¹
¹IAP - Goethe Universität, Frankfurt, Germany

The planned Facility for Antiproton and Ion Research (FAIR) is a new international accelerator laboratory at the GSI in Darmstadt, Germany. The main focus at this facility is aimed to heavy-ion research as well as protons and antiprotons colliding experiments. To produce these antiprotons (3 GeV), protons (29 GeV) will be aimed at a target (e.g. Copper). In order to focus these antiprotons for the storage in a synchrotron, a strong magnetic field will be applied by a so called magnetic horn. To generate the necessary high magnetic field for this application the designed stripline of the pulse forming network (PFN) has to handle a peak current of 400 kA with a pulse length of 20 μs. Currently the only possibility to handle this amplitude is mercury filled Ignitrons. Another application for high-power switches is the FAIR SIS injection and extraction magnets. The requirements for this switch are a hold-off voltage of about 80 kV and maximum currents of about 8 kA with a pulse length of a few μs.

The plasma physics working group at the University of Frankfurt develops a mercury free switch, which is able to replace the Ignitrons in the PFN of the magnetic horn. The challenge for the development of a switch for such high currents is to reduce the local electrode erosion. For that we propose a gas switch that generates an accelerated plasma to minimize the attrition.

The experimental setup of the switch consists of coaxial electrodes, similar to the geometry used for plasma focus devices [1]. To reach a high hold-off voltage, the setup is designed for the left hand side of the Paschen branch. One important feature of a high-voltage and high-current switch is the reliability for triggering. The main discharge between the coaxial electrode system will be initiated by a trigger pre-discharge. With an external triggering a gas breakdown is initiated at the outer electrodes and forms a conductive plasma sheath which penetrates through holes to the inner electrodes.

After the ignition of the main discharge between the coaxial electrode system and due to the interaction of the induced radial magnetic field with the plasma, the gas discharge will be accelerated to the open end of the coaxial electrode system. This acceleration of the plasma sheet is due to the Lorentz force, which interacts with the discharge. It is given by:

$$\vec{F} = \int dV \mathbf{J} \times \mathbf{B}$$

Therefore the switch will be called a Lorentz Drift Switch (LDS). For already designed LDSs the maximum current is 33 kA with a current rise time of 15 kA/μs. As a

* Work supported by a HGS-HIRe scholarship.

working gas Nitrogen and Argon were used.

For a further reduction of erosion and to provide enough charged particles for the current transport, several of these coaxial devices will be stacked together in a parallel, multiple electrode system. In order to synchronize the plasma sheets, the single tubes will be connected with each other across a vertical arrangement of boreholes at the outer electrodes. The following Fig. 1 shows a schematic drawing of the experimental set up of the first prototype of the multi-channel Lorentz Drift Switch.

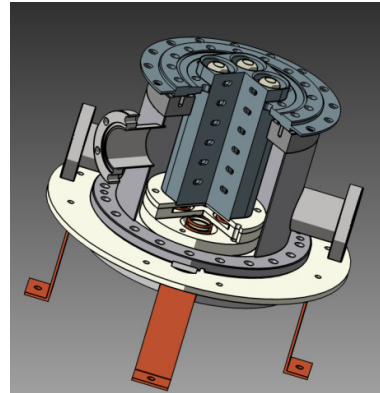

Figure 1: Schematic drawing of a multi-channel LDS.

The designed multi-channel LDS is a low inductive, fast current, low pressure gas discharge switch. Due to the simple setup and the reduction of erosion we will introduce a low cost, and rugged high-current switch for applications in further high-energy experiments. With the introduced setup we hope to provide a real alternative for such high-current applications, when common Ignitrons were used at FAIR so far.

References

- [1] J. Jacoby, C. Bickes, D.H.H. Hoffmann, C. Hofmann, J. Philipps, Experimental Study to Accumulate, Accelerate and Focus a Massive Plasma Beam onto a Target Fusion Engineering and Design 44 (1999) 331.
- [2] A. Görtler, "Untersuchungen von gepulsten Oberflächenladungen an Dielektrika und deren Anwendung zur Triggerung eines Pseudofunkenschalters", Diplomarbeit, Universität Erlangen-Nürnberg (1986)
- [3] M. Iberler, R. Bischoff, K. Frank, I. Petzenhauser, A. Rainer, J. Urban, Fundamental investigation in two flashover-based trigger methods for low-pressure gas discharge switches, IEEE on Plasma Science, Vol 32 (1), 208-214, 2004.