

Operation and Improvements of PHELIX*⁺

V. Bagnoud¹, C. Brabetz², U. Eisenbarth¹, J. Fils¹, S. Götte¹, T. Kühl^{1,3}, S. Kunzer¹, M. Kreutz¹,
D. Reemts¹, T. Stöhlker^{1,4}, L. Tymura¹, F. Wagner⁵, B. Zielbauer⁴

¹GSI, Darmstadt, Germany; ²Johann Wolfgang Goethe University Frankfurt, Germany; ³Johannes Gutenberg University Mainz, Germany; ⁴Helmholtz Institute Jena, Germany; ⁵Technical University Darmstadt, Germany

General overview

The general mission of GSI has undergone some tremendous changes in 2012 with the increased focusing of the laboratory's activities on the construction of FAIR. In view of the foreseen scarce ion-beamtime availability in the coming years, PHELIX¹, the high-energy short-pulse laser facility of GSI, has been used in 2012 almost exclusively to provide beamtime for users as well as internal developments.

Completed in 2008, PHELIX, a Helmholtz user facility opened to the international scientific community, is a dual front end high-energy laser capable of delivering long nanosecond high-energy as well as short sub-picosecond high-intensity laser pulses. It offers also a world-wide unique opportunity for combined ion-laser experiments to support the science programs of the Plasma Physics and Atomic Physics departments of GSI.

From an operation stand point, PHELIX supported 16 experiments distributed over 18 beamtimes and accounting for 245 shifts. The average duration of a beamtime at PHELIX including setup is about ten working days. At the end of 2012, nearly all remaining experiments in the backlog of approved experiment proposals have been scheduled for the beginning of 2013. A call for proposal has run in November and December and new experiments will be scheduled as soon as the evaluation process is over.

From a machine stand point and as recommended by the PHELIX advisory committee, the generation and amplification of temporally-clean short laser pulses has been a central issue for internal developments. In particular the development of an ultra-high temporal contrast module, the elimination of pre-pulses and the commissioning of plasma mirrors have been pursued

Operation of the laser facility

As can be seen in Figure 1, the time dedicated to user operation of the facility (experiment and setup time) exceeds 2/3 of the total time in 2012. This corresponds to nearly 35 weeks. This unusual high value has been dictated by the need to complete experiments in combination with the UNILAC before the 2013 shutdown. In order to provide this support, many important maintenance operations have been delayed. In particular, some repairs at the nanosecond front end have been postponed to 2013 and will result in a long downtime when they are being performed. In addition, the time dedicated to internal devel-

* The acronym stands for **P**etawatt **H**igh Energy **L**aser for heavy **I**on **eX**periments.

+ This work is supported by EMMI, the Helmholtz Institute Jena and GSI

opment has been reduced and internal development projects have been slowed down.

A recent feature of PHELIX that has been ramped up in the last years has been the use of the shot database (PSDB)². Besides recording all relevant shot data during operation, this database allows for generating statistics on the laser usage and performance. In the last 12 months, PHELIX has delivered about 3500 shots, from which 2500 shots are target shots while serving experiments. The low portion of failed experiment shots of 1.1 % demonstrates the reliability of the facility. So far, this does not include difference between effective and target parameters (energy, pulse duration etc...) as success criteria. The origin of a failed shot can be due to the machine and during test shots it is in majority due to debugging of the control system, which is normal. However, during beamtime the origin of failed shots is mostly due to the operators. For this reason, the failed shots are actively documented and the appropriate safety guards and checks are constantly added to the control system to help operators.

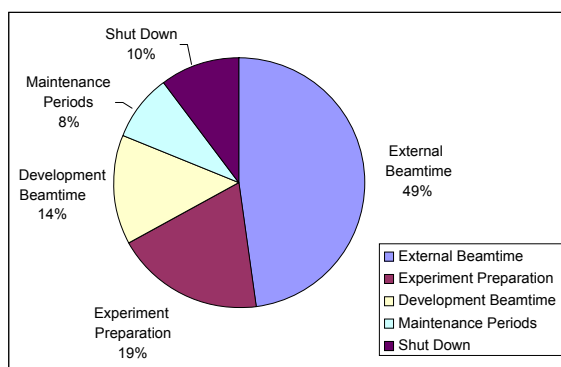

Figure 1: PHELIX usage in 2012

Internal developments and beamtime

An important development in the course of the year has been the first results and target shots with the temporal-contrast boosting module at PHELIX. In the last two years, the pump laser for this temporally-clean non-linear amplifier has been developed by the Helmholtz Institute Jena; and it led its first results at the beginning of the year. The module allows for a decrease of more than 4 orders of magnitude of the nanosecond pedestal of the pulse; and in the second part of the year a first glance at its impact on laser-driven proton acceleration has been done. More details about this work can be found elsewhere³. During this work, we discovered that the laser

temporal structure also includes weak pre-pulses that originate from the interplay between nonlinear effects in the amplifiers and internal reflections from the plan-parallel surfaces of optical components. These pre-pulses could be observed only when the general background was reduced sufficiently using the contrast boosting module. A way around this problem relies on the step-wise identification of defective optical components and their replacement with a component having wedged surfaces. However, this procedure is time consuming as the largest pre-pulses have been hiding pre-pulses of lower energy that must be taken care of in an iterative way⁴.

Similarly important for the temporal contrast of short laser pulses, the use of plasma mirrors as fast optical switches has been continued in collaboration with the STFC/Strathclyde University groups of Prof David Neely and Prof. Paul McKenna in the U. K. There, a characterization of the laser focus after the plasma mirror has been conducted at high energies, bringing new insights on the influence of the plasma mirror on the focus quality of the reflected laser pulses⁵.

On the infrastructure side, PHELIX has continued the upgrade of the petawatt target area to be able to operate at full power during the down-time of the accelerator and support user operation as well as the preparatory phase of the FAIR science program. After the successful integration of a new shielding scheme relying on 15 cm-thick steel plates aiming at containing radiation within the target area, the procurement and delivery of a target chamber with improved performance was realized. The new chamber, which can be seen in Figure 2, offers among others the possibility to work with two or more beams in order to build the pump-probe setups required by nearly all users.

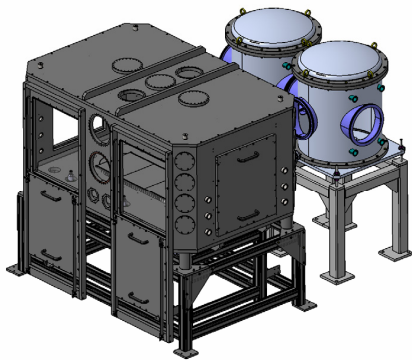

Figure 2: 3-D CAD view of the PHELIX target chamber

Another important infrastructure development concerns the end of chain sensor at the Z6 area that has been finalized and integrated in the PHELIX control system. This sensor is built on standard blocks (such as camera an energy attenuation systems) already used at other places of the laser and therefore easier to maintain than its predecessor. It includes also new features to ease the routine beam alignment together with spatial, energy and time information over the on-shot of both 1ω and 2ω pulses delivered at Z6.

Contribution to the scientific program and outreach

This year, 10 peer-reviewed articles^{6,7,8,9,10,11,12,13,14,15} were published on data collected at PHELIX. Typically, these publications report on results obtained during beam-time that occurred in the last 18 months.

In May, GSI held a joined meeting between IZEST¹⁶ and the people involved in the Helmholtz Beamline project. The 4-day meeting gathered more than 120 participants from around the globe to explore synergies between the IZEST proposal and the scientific program with lasers at FAIR. The variety of the presentations and the vitality of the discussions at the meeting showed the attractiveness and uniqueness of the Helmholtz beamline project for FAIR.

Outlook for 2013

In the last part of 2012, a call for proposal for experiments at PHELIX received a great success as the requested number of shifts exceeded the offer by a factor of three. The selected experiments will be planned starting in the second semester of 2013.

References

- [1] V. Bagnoud et al., Appl. Phys. B **100** (1), 137-150 (2010)
- [2] U. Eisenbarth et al., GSI Scientific Report 2011 /PNI-PP-02, 435 (2011)
- [3] F. Wagner et al., submitted to Optics Express
- [4] F. Wagner et al., this report
- [5] B. Zielbauer et al., this report
- [6] N. Kugland and al., Appl. Phys. Lett. **101**, 024102 (2012)
- [7] G. Scott et al., Appl. Phys. Lett. **101**, 024101 (2012)
- [8] B. Ecker et al., Optics Express **20** (23), 25391-25399 (2012)
- [9] D. Kraus et al., High Energy Density Physics **8** (1), 46-49 (2012)
- [10] M. Börner et al., Rev. Sci. Instrum. **83**, 043501 (2012)
- [11] I. Hofmann et al., Nuclear Instrum. and Meth. in Physics Research Section A: Accelerators, Spectrometers, Detectors and Associated Equipment **681**, 44 – 54 (2012)
- [12] A. Almomani et al., Phys. Rev. ST Accel. Beams, American Physical Society **15**, 051302 (2012)
- [13] P. Neumayer et al., Phys. Plasmas **19**, 122708 (2012)
- [14] M. M. Günther et al., Fus. Sci. and Technol. **61** (1), 231-236 (2012)
- [15] M. E. Povarnitsyn et al., Phys. Plasmas **19**, 023110 (2012)
- [16] <http://www.izest.polytechnique.edu>