

# THE 325 MHz FAIR pLinac LADDER RFQ - FINAL ASSEMBLY FOR COMMISSIONING

M. Schuett<sup>\*1,2</sup>, U. Ratzinger<sup>1</sup>, C. Kleffner<sup>2</sup>, K. Knie<sup>2</sup>

<sup>1</sup> Institute for Applied Physics, Goethe University, Frankfurt, Germany

<sup>2</sup> GSI Gesellschaft für Schwerionenforschung, Darmstadt, Germany

## Abstract

Based on the positive results of the unmodulated 325 MHz Ladder-RFQ prototype from 2013 to 2016, we developed and designed a modulated 3.4 m Ladder-RFQ. The Ladder-RFQ features a very constant voltage along the axis as well as low dipole modes. The unmodulated prototype accepted 3 times the operating power of which is needed in operation corresponding to a Kilpatrick factor of 3.1 with a pulse length of 200  $\mu$ s. The 325 MHz RFQ is designed to accelerate protons from 95 keV to 3.0 MeV according to the design parameters of the proton linac within the FAIR project. This particular high frequency for a 4-ROD-RFQ creates difficulties, which triggered the development of a Ladder-RFQ with its high symmetry. The results of the unmodulated prototype have shown, that the Ladder-RFQ is very well suited for that frequency. For the applied cooling concept, the Ladder-RFQ can be driven up to a duty factor of 10%. Manufacturing has been completed in September 2018. The final flatness & frequency tuning as well as the final assembly have been completed. We present the final RF measurements and assembly steps getting the Ladder-RFQ ready for shipment and high power RF test prior to assembly.

## INTRODUCTION

The idea of the Ladder type RFQ firstly came up in the late 1980s [1, 2] and was realized successfully for the CERN Linac3 operating at 101 MHz [3] and for the CERN antiproton decelerator ASACUSA at 202 MHz [4].

Due to its high symmetry, this Ladder-RFQ features a very constant voltage along the axis well-suited for high frequency operation and duty factors up to 10%. A modified short (0.7 m) and non-modulated Ladder-RFQ prototype was high power tested at the GSI test stand [5]. It accepted three times the RF power level needed in operation [6, 7]. That level corresponds to a Kilpatrick factor of 3.1 with a pulse length of 200  $\mu$ s.

According to the design parameters of the proton linac within the FAIR project, the 325 MHz RFQ [6] (see Fig. 1) is designed to accelerate protons from 95 keV to 3.0 MeV [8, 9]. This particular high frequency creates difficulties for a 4-ROD type RFQ. Yet the results of the unmodulated prototype have shown, that the Ladder-RFQ is a suitable candidate for that frequency, which triggered the development of a classical Ladder-RFQ with its higher symmetry. The basic design and tendering of the RFQ have been successfully completed in 2016 [6]. Manufacturing and copper-plating of

the tank have been succeeded in September 2018. The final machining step for both flatness and frequency tuning has been finished in April 2019. Afterwards, the final assembly including vacuum components, frequency plungers, motor-driven plungers, RF coupler and cooling has been completed (see Figs. 2 and 3).

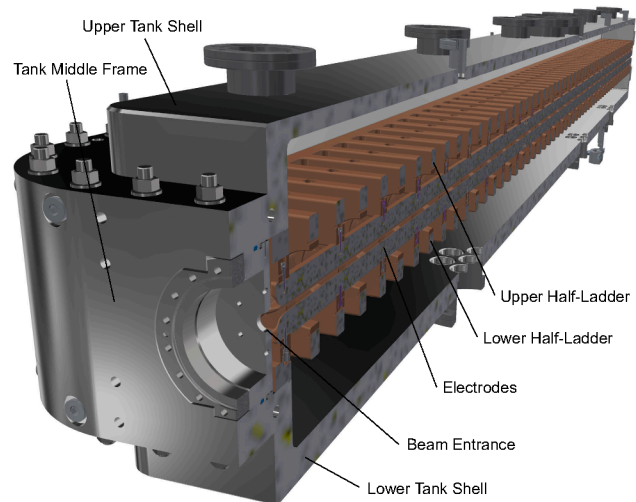

Figure 1: Cut view of the Ladder RFQ showing the individual components.

## DESIGN AND MANUFACTURING

The mechanical design consists of an inner copper ladder structure mounted into an outer stainless steel tank. The tank is divided into three parts - the lower and upper shells and a middle frame (see Fig. 1). The lower shell of the tank carries and fixes the position of the inner resonating ladder structure. Due to manufacturing reasons, the ladder structure is divided into two lower and two upper half-ladder elements, which are precisely aligned via guide pins. The half-ladders themselves are machined from solid copper blocks. Between the half-ladder elements, the electrodes are precisely fixed via carrier-rings [10] (see Fig. 4). Those carrier-rings furthermore guarantee a seamless RF connection between the electrodes and the ladder structure.

The RF features are mainly determined by the resonating structure, while the dimensions of the tank have no significant influence on the frequency. Based on the successful high power tests of the unmodulated prototype, we decided to develop a new beam dynamics for a vane-vane voltage of 88 kV. For details of the final beam dynamics and error studies, see [11, 12]. The basic physical and mechanical

\* schuett@iap.uni-frankfurt.de / m.schuett@gsi.de

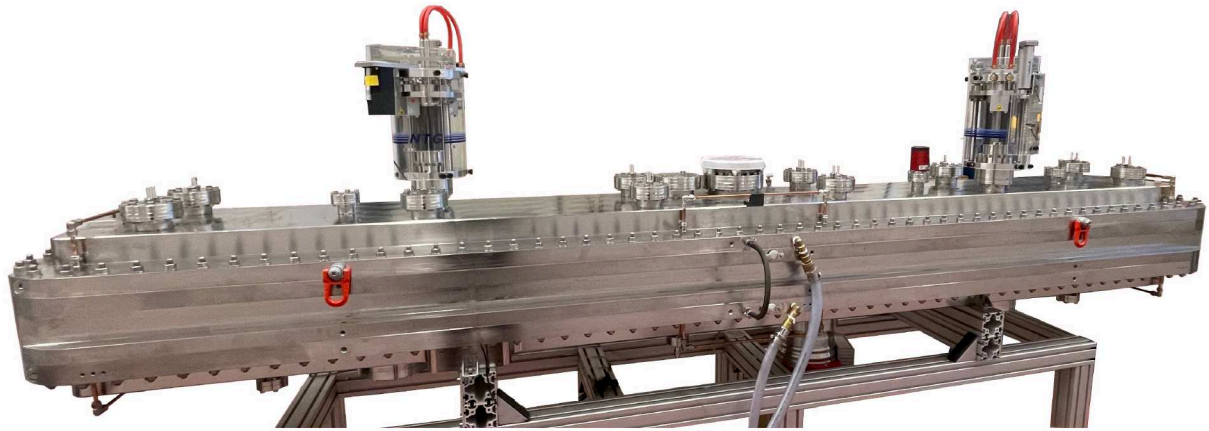

Figure 2: Photo of the Ladder RFQ including assemblies: 10 static frequency plungers, 2 movable frequency plungers and the cooling system.

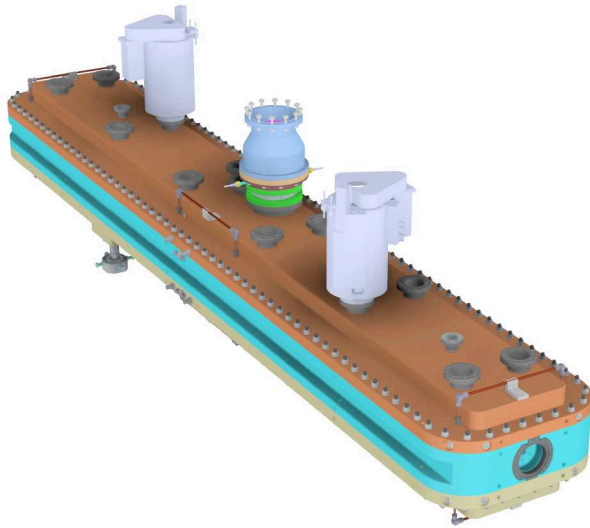

Figure 3: Digital Mockup of the Ladder RFQ including the subcomponents RF coupler, motor driven frequency plungers and the cooling system.

parameters of the Ladder-RFQ results are shown in Table 1. Furthermore, the thickness of the tank walls inside the entrance and exit flange of the RFQ has been reduced to 10 mm within the flange diameter of 100 mm (CF100). That allows an integration of preceding and following components like a cone or steerer to reduce an emittance growth caused by an additional drift. Additionally, the effect of gap fields between the electrodes and tank wall has been studied to improve the overall beam dynamics [13].

### FINAL ASSEMBLY

The manufacturing and first assembly of the RFQ has been completed in September 2018 [14]. RF measurements took place in 2019. Since then the subsystem for the final assembly have been designed, machined and installed (see Figs. 2 and 3). The frequency measurement after the

Table 1: Main RF and Geometric Parameters of the Modulated Ladder-RFQ

No. of RF cells	55
Q-Value (sim./meas.)	6800/5700
Loss (with meas. Q)	≈ 800 kW
Shunt Impedance (sim.)	40 kΩm
Vane-Vane Voltage	88.43 kV
Energy Range	95 keV - 3 MeV
Frequency	325.224 MHz
Repetition Rate	4 Hz
Pulse Duration	200 μs
Total Length	3410 mm
Cell Length	40 mm
Spoke Height	280 mm
Spoke Width	150 mm
Electrode Length	3327 mm

full assembly including RF and vacuum sealings without frequency plungers resulted in 324.4 MHz, i.e. 640 kHz below the operating frequency. The static frequency plungers (see Fig. 5) have been designed to maximise the overall frequency shift. The plungers consist of a cnc machined cylinder which is welded on a CF63 flange. The plunger is entirely water cooled and copper plated. After assembly of 10 static plungers the frequency rose to 325.13 MHz in air. The two motor driven plungers are capable of additionally increasing the frequency by 400 kHz.

Besides the cooling system has been installed. The cooling channels are directly integrated into the copper structure and externally connected by copper pipes which are fixed by L-shaped stabilisers on the tank. There are no sealings between vacuum and water as the circuit is fully closed within the tank. The water pipes are externally connected by exchangeable radially rubber sealed Swagelok fittings.

Currently, the RF coupling loop is being machined and assembled. Within the volume of the flange the loop has an additional bracket attached in order to reduce the distance

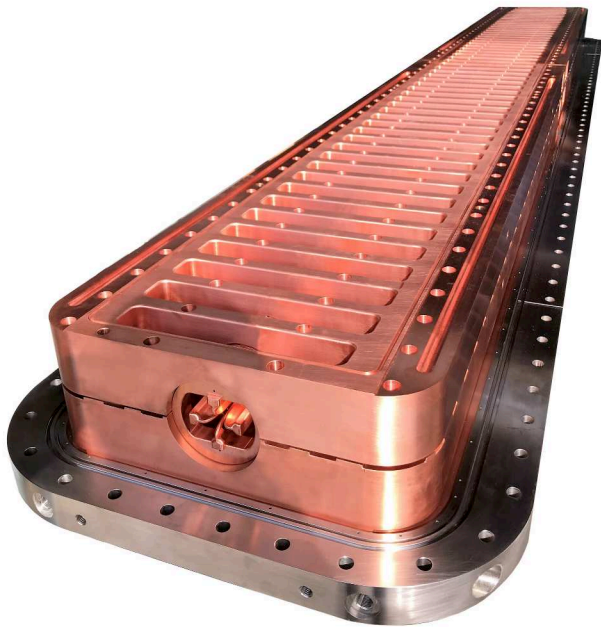

Figure 4: RF ladder structure during assembly and before closing the tank.

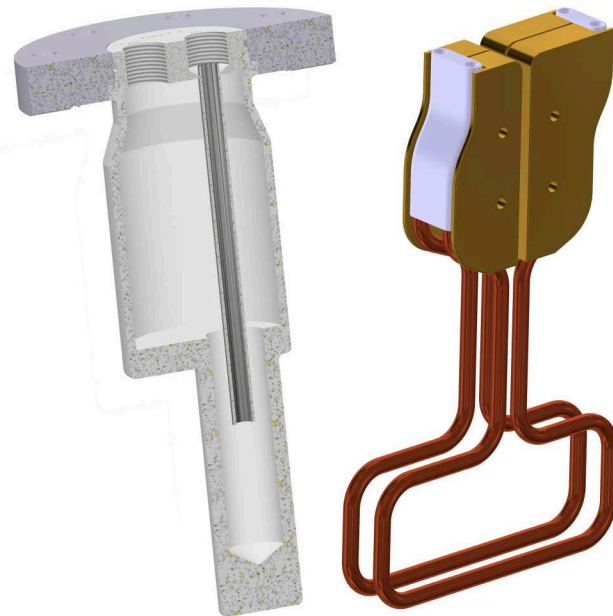

Figure 5: Left: Mechanical design of the static frequency plungers. Right: Mechanical design of the coupling loop.

between both electrical connectors and maintain  $50\ \Omega$  until the loop has entered the cavity volume. By this technique the coupling into the cavity should be increased and losses within the flange reduced.

Finally, a beam cone has been designed and is currently under construction (see Fig. 6). The cone is made of WoCu to reduce sputtering and vacuum soldered into a CF flange. The cone penetrates the RFQ flange in order to reduce distances and emittance growth. The cone is capable of catching the maximum extractable proton beam with 100 mA and 95 keV

at 2.7 Hz 7 ms resulting in an average power dissipation of 180 W.

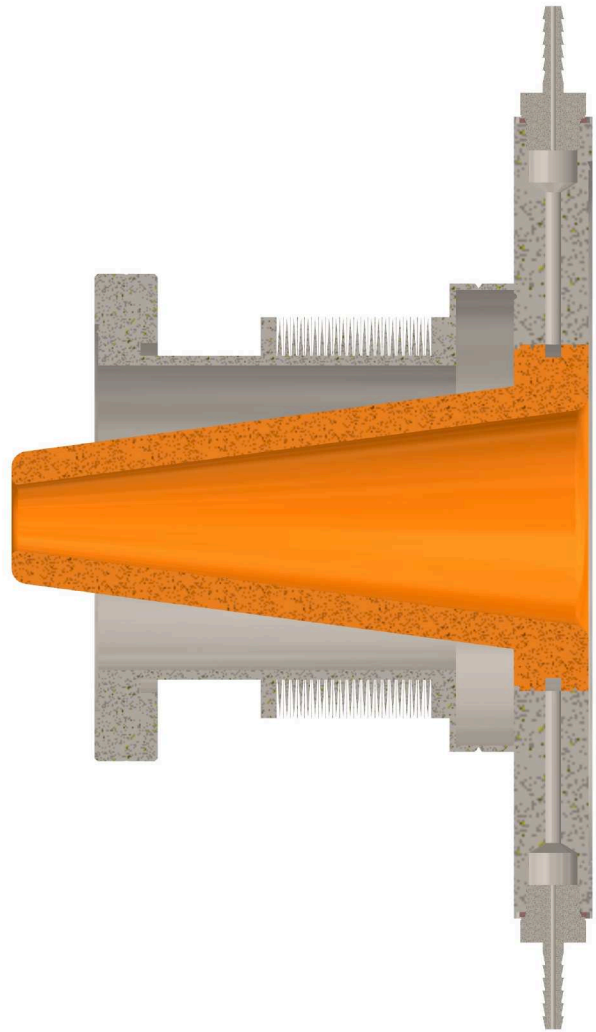

Figure 6: Cut view of the beam catcher cone.

## OUTLOOK

The Ladder RFQ assembly of all subsystems, i.e. cooling static & movable frequency tuning and vacuum has been completed. The coupling loop is currently in manufacturing and needs to be tested. Finally, the Ladder RFQ has to pass high power tests, which will be done at GSI, Darmstadt, as soon as the modulator is available and the coupling loop successfully has proven its functionality. After completion of the FAIR pLinac building the Ladder RFQ will see first beam together with the already operable source and LEBT delivered by CEA.

## REFERENCES

- [1] A. Fabris, A. Massarotti, M. Vretenar, "A model of 4-rods-RFQ", *Seminar on New Techniques for Future Accelerators*, pp. 265-269, Erice, Sicily. 1986.

- [2] M. Browman, T. Barts, P. Friedrichs, and G. Spalek, "Studies of the Four-Rod RFQ Using the MAFIA Codes", in *Proc. LINAC'88*, Newport News, VA, USA, Oct. 1988, paper MO3-33, pp. 119-121.
- [3] G. Bezzon *et al.*, "Construction and Commissioning of the RFQ for the CERN Lead-Ion Facility", in *Proc. LINAC'94*, Tsukuba, Japan, Aug. 1994, paper TH-12, pp. 722-724.
- [4] Y. Bylinsky, A. Lombardi, and W. Pirkel, "RFQD: A 'Decelerating' Radiofrequency Quadrupole for the CERN Antiproton Facility", in *Proc. LINAC'00*, Monterey, CA, USA, Aug. 2000, paper TUD05, pp. 554-556.
- [5] G. Schreiber, E. Plechov, J. Salvatore, B. Schlitt, A. Schnase, and M. Vossberg, "First High Power Tests at the 325 MHz RF Test Stand at GSI", in *Proc. LINAC'16*, East Lansing, MI, USA, Sep. 2016, pp. 287-289. doi:10.18429/JACoW-LINAC2016-MOPLR067
- [6] M. Schuett, U. Ratzinger, A. Schnase, M. Syha and M. Obermayer, "Status of the modulated 3 MeV 325 MHz Ladder-RFQ", *Journal of Physics: Conference Series*, vol. 874, pp. 012048, IOP Publishing, Jul. 2017. doi:10.1088/1742-6596/874/1/012048
- [7] M. Schütt, M. A. Obermayer, U. Ratzinger, and A. Schnase, "Development and Measurements of a 325 MHz RFQ", in *Proc. LINAC'16*, East Lansing, MI, USA, Sep. 2016, pp. 578-580. doi:10.18429/JACoW-LINAC2016-TUPLR053
- [8] C. M. Kleffner *et al.*, "Status of the FAIR Proton Linac", in *Proc. LINAC'18*, Beijing, China, Sep. 2018, pp. 787-789. doi:10.18429/JACoW-LINAC2018-THPO046
- [9] C. M. Kleffner *et al.*, "Status of the FAIR Proton LINAC", in *Proc. IPAC'19*, Melbourne, Australia, May 2019, pp. 889-891. doi:10.18429/JACoW-IPAC2019-MOPTS020
- [10] U. Ratzinger, K. Kaspar, E. Malwitz, S. Minaev and R. Tiede, "The GSI 36MHz high-current IH-type RFQ and HIIF-relevant extensions", *Nucl. Instrum. Methods Phys. Res., Sect. A*, vol. 415, pp. 281-286, 1998. doi:10.1016/S0168-9002(98)00395-7
- [11] M. Syha, U. Ratzinger, and M. Schuett, "Beam Dynamics for the FAIR p-Linac Ladder RFQ", in *Proc. LINAC'18*, Beijing, China, Sep. 2018, pp. 522-524. doi:10.18429/JACoW-LINAC2018-TUPO083
- [12] M. Syha, H. Hähnel, U. Ratzinger, and M. Schuett, "New Beam Dynamics Simulations for the FAIR p-Linac RFQ", in *Proc. IPAC'19*, Melbourne, Australia, May 2019, pp. 921-924. doi:10.18429/JACoW-IPAC2019-MOPTS032
- [13] M. Schuett, M. Syha, U. Ratzinger, "Compensation of longitudinal entrance and exit gap field effects in RFQ's of the 4-ROD type" *Nucl. Instrum. Methods Phys. Res., Sect. A*, vol. 928, pp. 58-64, 2019. doi:10.1016/j.nima.2019.02.071
- [14] M. Schuett, U. Ratzinger and M. Syha, "Progress of the modulated 325 MHz Ladder RFQ", *Journal of Physics: Conference Series*, vol. 1067, pp. 052004, IOP Publishing, Sep. 2018. doi:10.1088/1742-6596/1067/5/052004